

**Acorn Stair Lift Proposal**

Acorn Stair Lift System ----- \$2,895.00

R - Handed

L - Handed 5 Year limited Warranty

Acorn Stair Lift System ----- \$2,495.00

R - Handed

L - Handed 2 Year Limited Warranty

Acorn Stair Lift System ----- \$2,295.00

R - Handed

L - Handed 1 Year Limited Warranty

**Options**

Hinged Rail Option ----- \$465.00

Heavy Duty Capacity ----- \$450.00

Rail Extension Kit ----- \$420.00

Life Time Battery Warranty ----- \$350.00

Date \_\_\_\_\_

Installed system complete with the above listed options \$ \_\_\_\_\_

The above cost estimates are good for 60 days from date of proposal, a sales and installation agreement must be executed prior to the start of any installation.

## Warranty Information

### SFAL / Cam-Med 5 Year Limited Warranty

SFAL/ Cam-Med (Years 1-3) warrants that the Acorn System will be installed in a workmanlike manner and that all parts and accessories, including labor will be 100% covered from defects in material and workmanship for (3) three years from the date the System is delivered to Customer.

SFAL/ Cam-Med (Years 4-5) will provide warranty coverage for the last (2) two years that will discount any necessary repairs to the Acorn System that includes all parts, accessories, and labor discounted 50% of the current Cam-Med MSRP + Labor hours.

**\*\*Excluding the following items and conditions:** This warranty excludes batteries, any damage caused by misuse or neglect, tampering and or self inflicted damage. It also excludes any weather or electrical surge related damage to the electrical components of this system.

### SFAL / Cam-Med 2 Year Limited Warranty

SFAL/ Cam-Med (Year 1) warrants that the Acorn System will be installed in a workmanlike manner and that all parts and accessories, including labor will be 100% covered from defects in material and workmanship for (1) one years from the date the System is delivered to Customer.

SFAL/ Cam-Med (Year 2) will provide warranty coverage for the last (1) one year that will discount any necessary repairs to the Acorn System that includes all parts, accessories, and labor discounted 50% of the current Cam-Med MSRP + Labor hours.

**\*\*Excluding the following items and conditions:** This warranty excludes batteries, any damage caused by misuse or neglect, tampering and or self inflicted damage. It also excludes any weather or electrical surge related damage to the electrical components of this system.

### SFAL / Cam-Med 1 Year Limited Warranty

SFAL/ Cam-Med warrants that the Acorn System will be installed in a workmanlike manner and that all parts and accessories, including labor will be 100% covered from defects in material and workmanship for (1) one year from the date the System is delivered to Customer.

**\*\* Excluding the following items and conditions:** This warranty excludes batteries, any damage caused by misuse or neglect, tampering and or self inflicted damage. It also excludes any weather or electrical surge related damage to the electrical components of this system.

## **Business History / Certifications / Insurance Certificates**

---

- **20 + years servicing and installing Stair lift Systems, Overhead patient Lifting Systems, Ramping Systems, and related equipment.**
  - **Accredited A+ Rating with the Better Business Bureau**
  - **Pa Attorney General HIC Registration # PA025940**
  - **Pa Office of Long Term Living – MA # 102635459**
- 

## **Manufacture Certification**

- **Acorn Stair Lifts**
  - ~~Medi Tek Stair Lifts~~
  - ~~Bruno Stair Lifts (Picture Perfect )~~
  - ~~Horcher Lifting Systems~~
  - ~~Liko / Hill-Rom Lifting Systems~~
- 

## **Insurance Coverage**

- **Western Heritage Ins. Co.**  
**Liability Policy ..... # SCP0813701 (exp 12/01/12)**
- **Travelers Ins. Co.**  
**Auto Insurance Policy..... # 581189**
- **SWIF Insurance Fund**  
**Workers Compensation Policy..... # 05721481**

# Regain THE freedom OF YOUR HOME



## The Acorn Superglide Stairlift

The Acorn Superglide Stairlift is one of the most technologically advanced stairlifts available, helping thousands of people worldwide to reclaim full access to their home. It's the safe, comfortable and simple solution to difficulty with the stairs.

Every aspect of the Acorn Superglide has been designed for the highest standards of comfort and safety. Our years of experience have helped us to create a stairlift that is built purely with the user in mind.

The Acorn Superglide is powered by a maintenance free DC power pack, which ensures your lift works even in the event of a power cut.

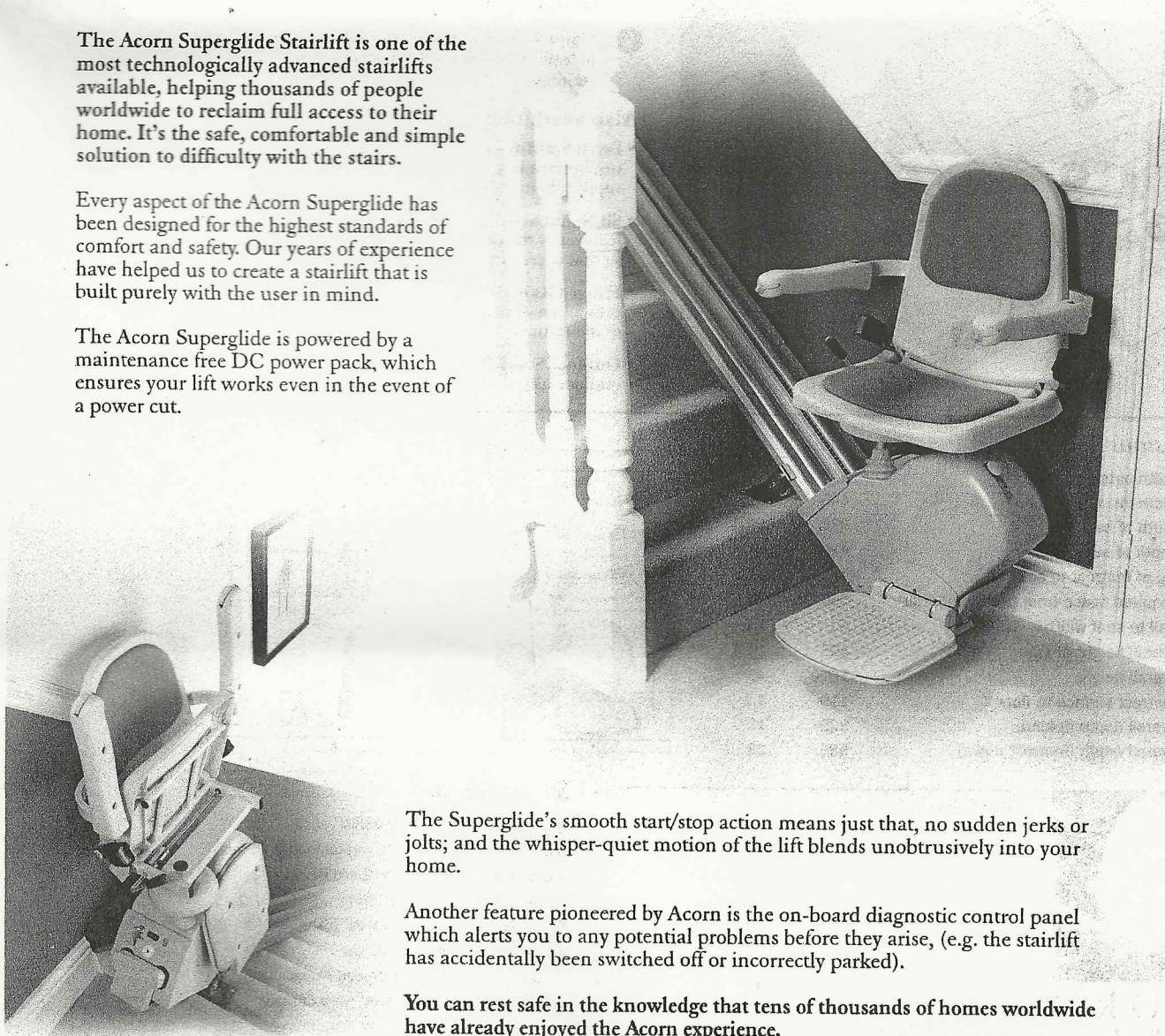

The Superglide's smooth start/stop action means just that, no sudden jerks or jolts; and the whisper-quiet motion of the lift blends unobtrusively into your home.

Another feature pioneered by Acorn is the on-board diagnostic control panel which alerts you to any potential problems before they arise, (e.g. the stairlift has accidentally been switched off or incorrectly parked).

You can rest safe in the knowledge that tens of thousands of homes worldwide have already enjoyed the Acorn experience.

GIVE YOUR LIFE A LIFT<sup>®</sup>

# A WEALTH OF *features* FOR YOUR BENEFIT

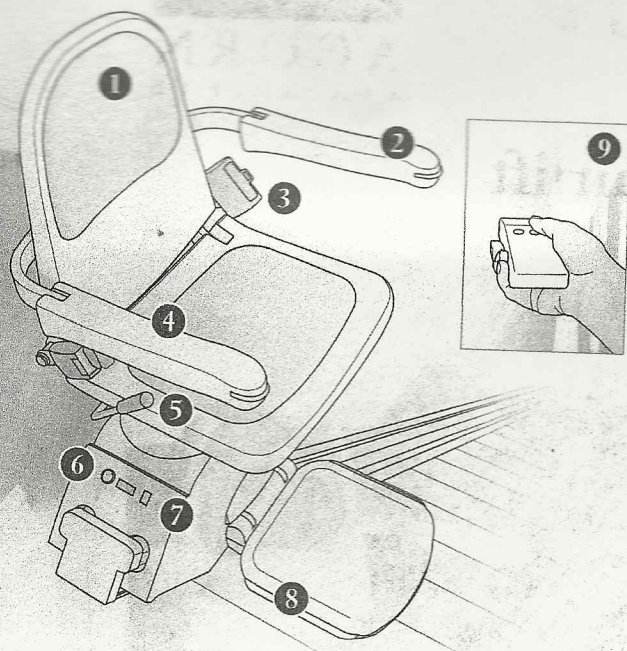

- ① Padded seat and backrest.
- ② Easy to use controls.
- ③ Secure safety belt.
- ④ Folding arms, footrest and seat allow easy access to the stairway.
- ⑤ Swivel seat - no need for twisting the body to get on and off the lift.
- ⑥ Lockable on/off switch allows the user to prevent others (e.g. children) from using the lift.
- ⑦ Diagnostic digital display informs the user of the status of the lift.
- ⑧ Five safety sensors on the footrest and carriage stop the lift automatically if any obstruction is encountered.
- ⑨ Hand-held remote controls allow users to 'call' or 'send' the lift up and down the staircase.

### Also available:

- **Perch Stairlift** - ideal for when the user may have trouble bending at the knee. Features ergonomic support handles for added security.
- **Sit/Stand Stairlift** - this model combines the features of the perch stairlift with the standard lift so that users can choose to sit or stand.
- **Hinged Rail** - for when a standard rail may present an obstruction to a doorway at the foot of the stairs.
- **Outdoor Stairlift** - fully weather-proofed for outdoor use.

### Dimensions

		mm	inches
A	Width outside armrests	560	22
B	Width inside armrests	445	17.5
C	Width of backrest	370	14.5
D	Depth of seat	410	16
E	Top of footrest to seat	445	17.5
F	Required space from bottom of stair	660	26
G	Wall to seat width	40	1.5
H	Overall height of seat	495	19.5
I	Overall height	1020	40
J	Footrest surface to floor	115	4.5
K	Overall depth (folded)	325	13
L	Overall depth (footrest down)	585	23

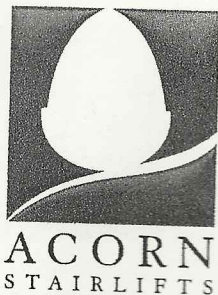
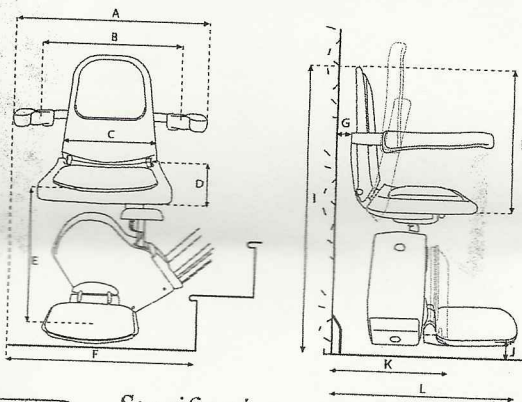

Dealer Stamp

### Specifications

Motor Power	0.25KW
Motor Output Speed	No greater than 0.15 m/s
Method of Drive	Rack and Pinion
Motor Output Torque	108Nm
Power Supply	24V DC (battery)
Maximum Capacity	127kgs
Track	Extruded Aluminium
Mains Supply	UK 240V, 50Hz Charger
	EC 220V, 50Hz Charger

Acorn, in keeping with its policy of continual development, reserves the right to change specifications without notice. All measurements are approximate. Images are shown for illustrative purposes only. Product may vary slightly.

ACIND/EXP0108

GIVE YOUR LIFE A LIFT®

# Independence

MADE *easy*

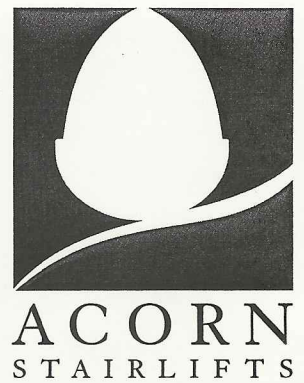

## The Acorn 80 Curved Stairlift

With the Acorn 80 Curved Stairlift, there's no longer any need to compromise your independence and struggle with the stairs in your home. Caring about your personal needs, Acorn truly can provide a solution that will make life easier for you. Whatever the reason, you can be proud to join the thousands of people all over the world who enjoy independent living at home, thanks to the Acorn 80.

With a built-in soft start and stop facility, the Acorn 80 gives you a smooth comfortable ride every time, and you can be sure that your stairlift is always ready for use thanks to the integral rechargeable battery pack, even in the event of a mains power failure.

The Acorn 80 fits practically any curved staircase, and its slim, attractive rail fits to your stairs, so there's no damage to your home. Together with a smooth, quiet operation, an Acorn Stairlift is an attractive addition to any home.

The Acorn 80 has been carefully designed to include a wide variety of comfort and safety features, to provide you with many years of safe and reliable enjoyment of your stairlift. To ensure your lift is simple and effortless to operate, the Acorn 80 has also been designed with ease of use and comfort in mind.

The unique self-levelling transport system moves the stairlift carriage along the low profile rail and automatically adjusts the speed and level of the seat when moving round corners, providing an exceptionally smooth ride. The stairlift's electronic programming ensures optimum performance at all times.

The footrest of the Acorn 80 is extremely close to the ground floor level, and has no step; also it ends level with the top stair nose, giving easy access to the landing.

When not in use, the Acorn 80 can be folded away; its slim profile and unique inside parking ability ensures that the staircase is not obstructed, allowing other members of the household to use the stairs as normal.

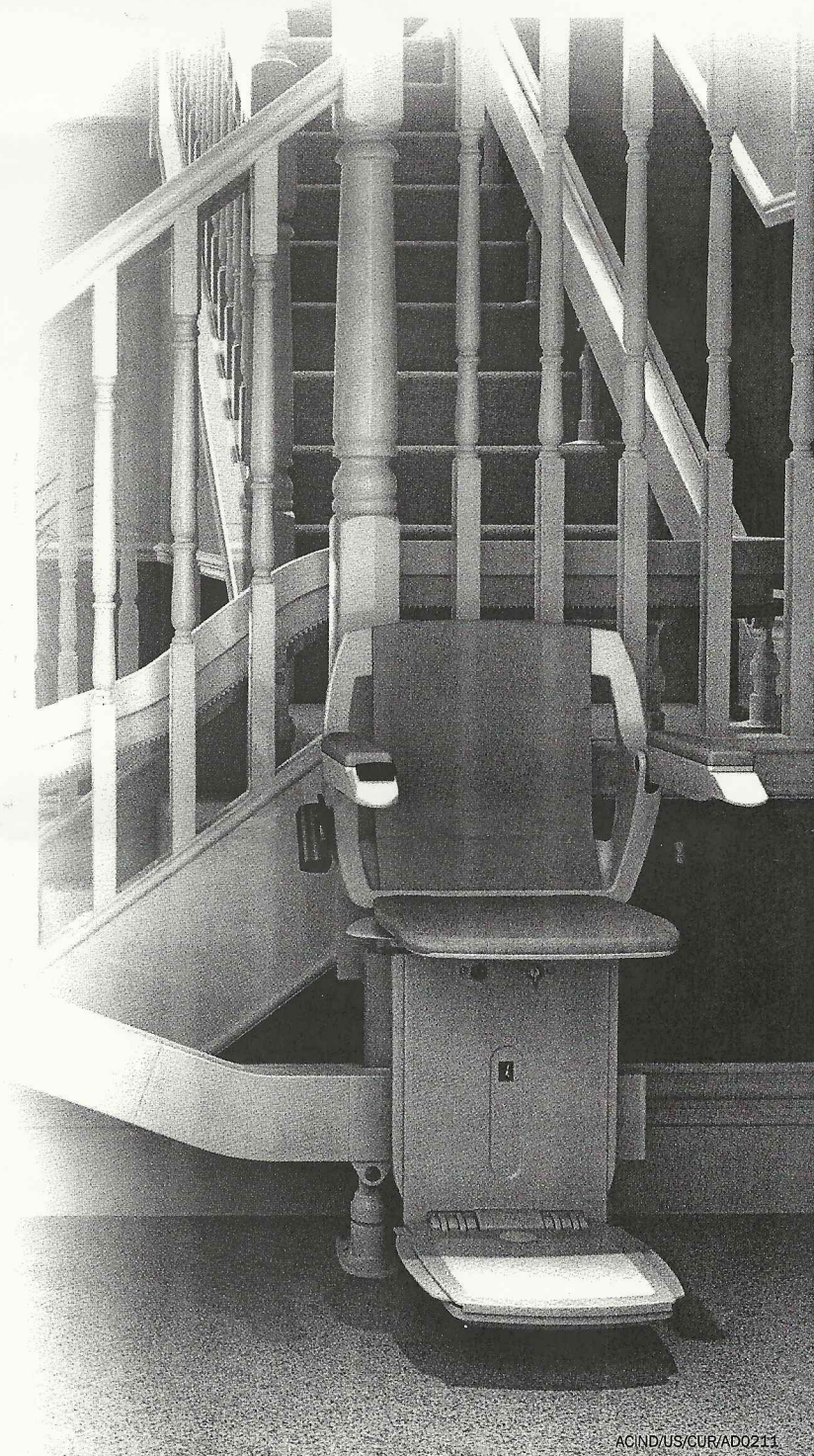

A WEALTH OF

# features

FOR YOUR BENEFIT

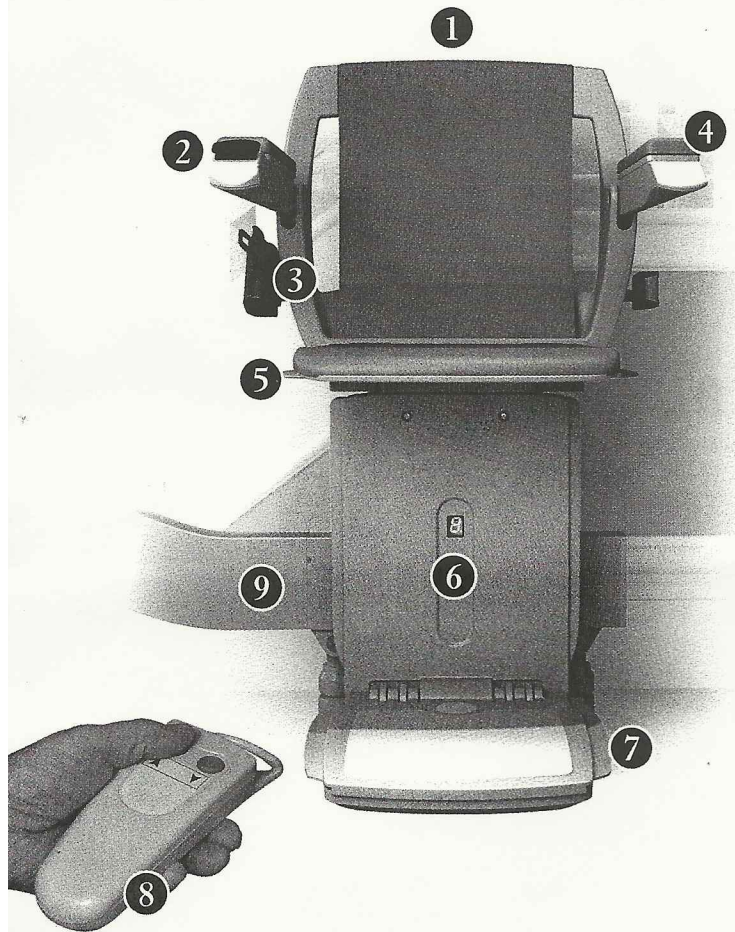

- 1 Padded seat and backrest.
- 2 Easy to use controls.
- 3 Secure safety belt.
- 4 Folding arms, footrest and seat allow easy access to the stairway.
- 5 Swivel seat - no need for twisting the body to get on and off the lift.
- 6 Diagnostic digital display informs the user of the status of the lift.
- 7 Safety sensors on the footrest and carriage stop the lift automatically if any obstruction is encountered.
- 8 Hand-held remote controls allow users to 'call' or 'send' the lift up and down the staircase.
- 9 Modular rail allows the rail portion of the lift to be quickly assembled from stock components, enabling faster delivery and an installation time to suit you.

## Dimensions

	mm	inches
A Floor to top of footrest	50	2
B Top of footrest to top of seat	490-580	19-23
C Top of seat to top of arms	247	9.7
D Top of arms to top of seat back	203	8
E Width between armrests	450	18
F Overall width	567	22
G Overall height	950-1030	37-41
H Length of arms from seat back	400	16
I Length of seat base from seat back	370	15
J Length of footrest	365	14
K Width of footrest	375	15
L Front of footrest to stringer	640	25
M Back of seat to stringer	90	3.5
N Folded width	320	13

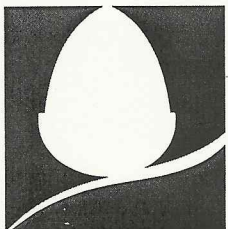
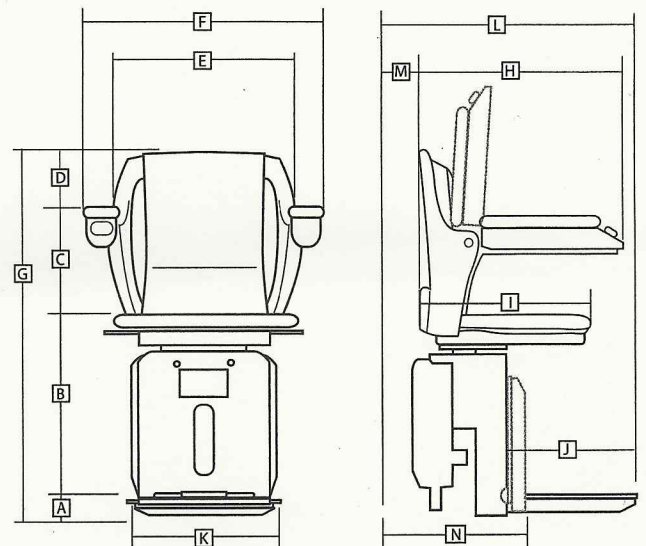

**ACORN**  
STAIRLIFTS

Dealer stamp:



Acorn, in keeping with its policy of continual development, reserves the right to change specifications without notice. All measurements are approximate. Images are shown for illustrative purposes only. Product may vary slightly.

GIVE YOUR LIFE A LIFT®